

FIBER BRAGG GRATING

IXC-FBG-PS-M

Ultra-Narrow Band-Pass Filter Module

This all fiber-based filter provides a clean extraction of narrow-band signal, Full Width Half Maximum (FWHM) could be selected at time of order from 1 to 4 GHz. Filter shape exhibits a flat-top shape in order to preserve signal integrity, steep edges and a high crosstalk over the full C or L band to remove all unwanted signals and noises.

The all-fiber design with no moving part ensures long time reliability. Fiber Bragg Gratings used in the module are thermally packaged in order to get a very stable central wavelength against lab temperature variations.

Thanks to our dedicated packaging, the bandpass wavelength can be easily and finely adjusted by user by rotating a tiny screw on the package.



Benefits & Features

- Flat-top symmetrical pass-band filter
- Down to 1 GHz (8 pm) FWHM
- < 4 dB Insertion Loss
- > 25 dB Optical Rejection Ratio @ 10 GHz
- PM or SMF
- ± 100 pm fine tuning!

Applications

- Microwave photonics
- Quantum communication
- Space communication
- Lidar
- Lines filtering for lasers and sensors
- RF filtering
- ASE or laser mode suppression
- Linewidth reduction
- Frequency discriminator

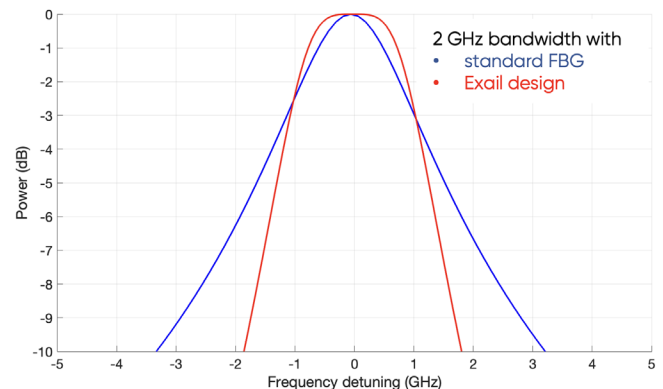
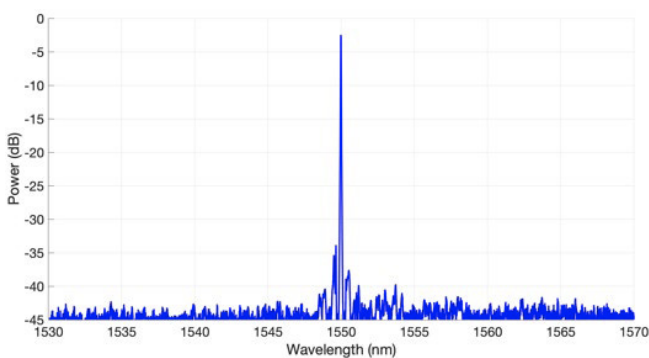

Typical response (IN → OUT)

Flat-top symmetrical band-pass design with an improved Q-factor, leading to better selectivity and higher signal-to-noise ratio.

IXC-FBG-PS-M

Ultra-Narrow Band-Pass Filter Module

TECHNICAL SPECIFICATIONS

Parameters

Band-pass center wavelength CW ¹ (nm)	1520 1610 (TBD)
Band-pass bandwidth B (FWHM) ² (GHz)	1, 2, 3 or 4 (TBD) ± 0.5
Insertion loss IL (dB)	< 4
Out-of-band attenuation ΔT at ±10 GHz (dB)	> 25
Rejection bandwidth (IN → OUT)	C-band or L-band
Tuning range (pm)	± 100
Tuning resolution (GHz)	1
CW thermal drift [-5 ; 70]°C (pm)	< 150
Packaging (mm)	165 x 55 x 15
Input power (max.) ³⁻⁴ (mW)	500
Pigtail length (m)	0.5
Optical connectors CC	FC/APC, FC/PC, SC/PC, SC/APC (0.9 mm buffered fiber)

¹ Referenced to vacuum at ± 0.05 nm, slow axis (PM Fiber)

² Lorentzian line shape for standard 1 GHz FWHM

³ Maximum input power: damage power threshold

⁴ Recommended input power for stable filter operation is below 2 mW for 1GHz and below 10 mW for 2 to 4 GHz FWHM version

Ordering Information

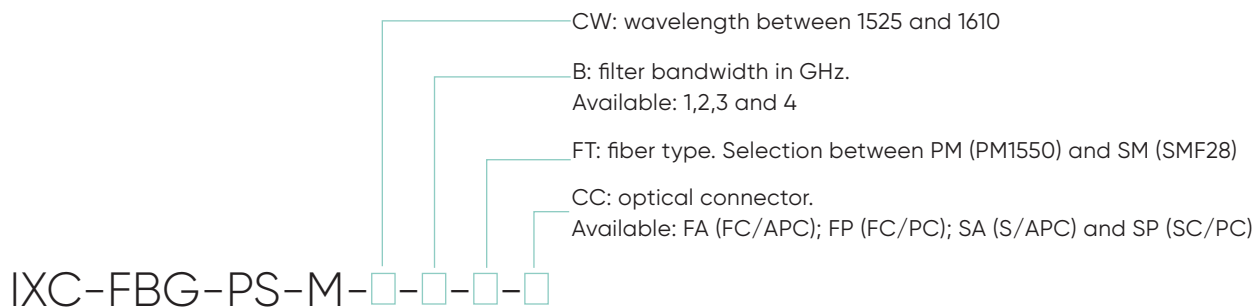

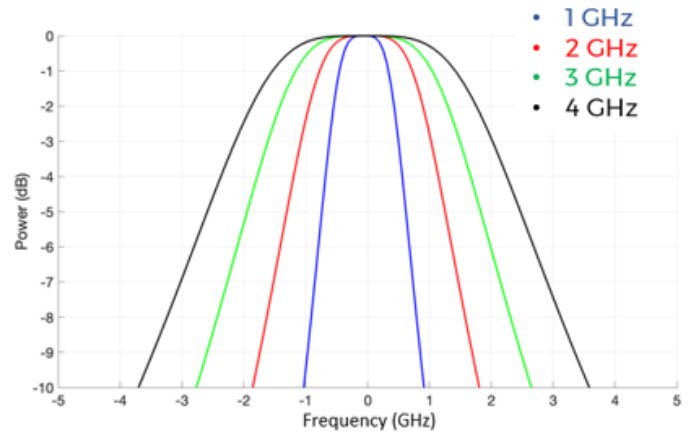
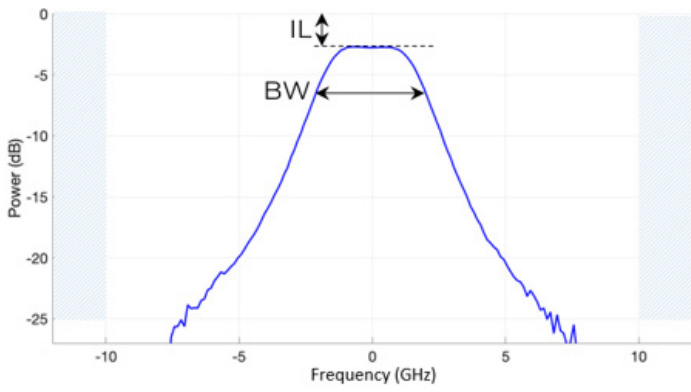

Typical response (IN → OUT)

This filter allows transmission of a specific narrow band while rerouting other wavelengths in C or L-band. Several bandwidths are available ranging from 1 to 4 GHz.

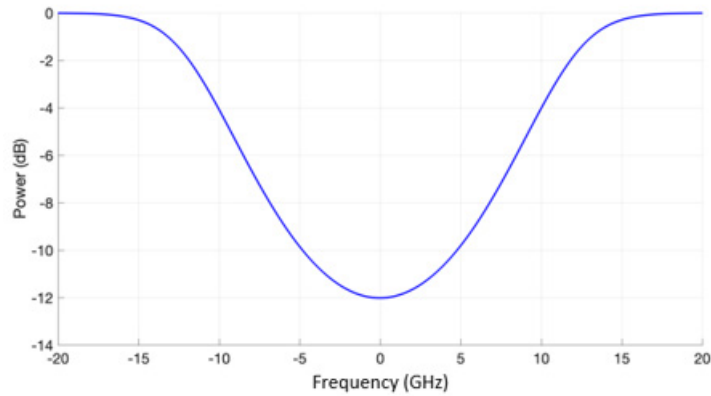

Typical response (IN → REJ)

Packaging

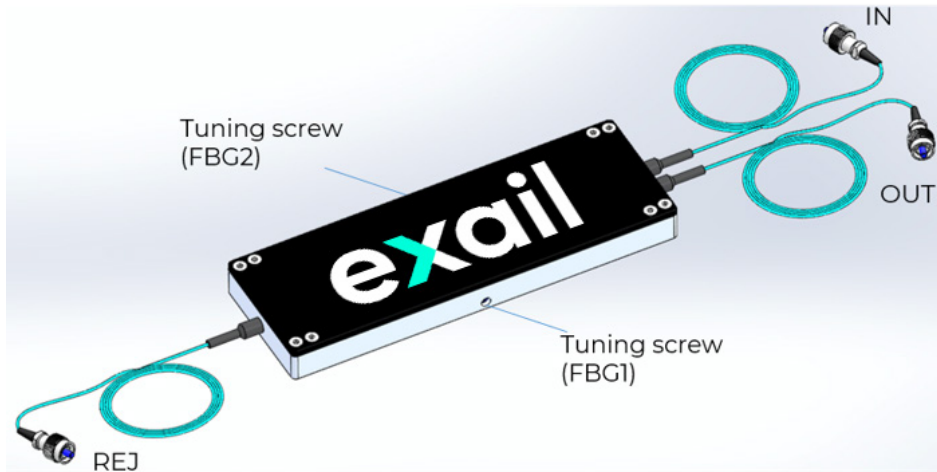

Configuration

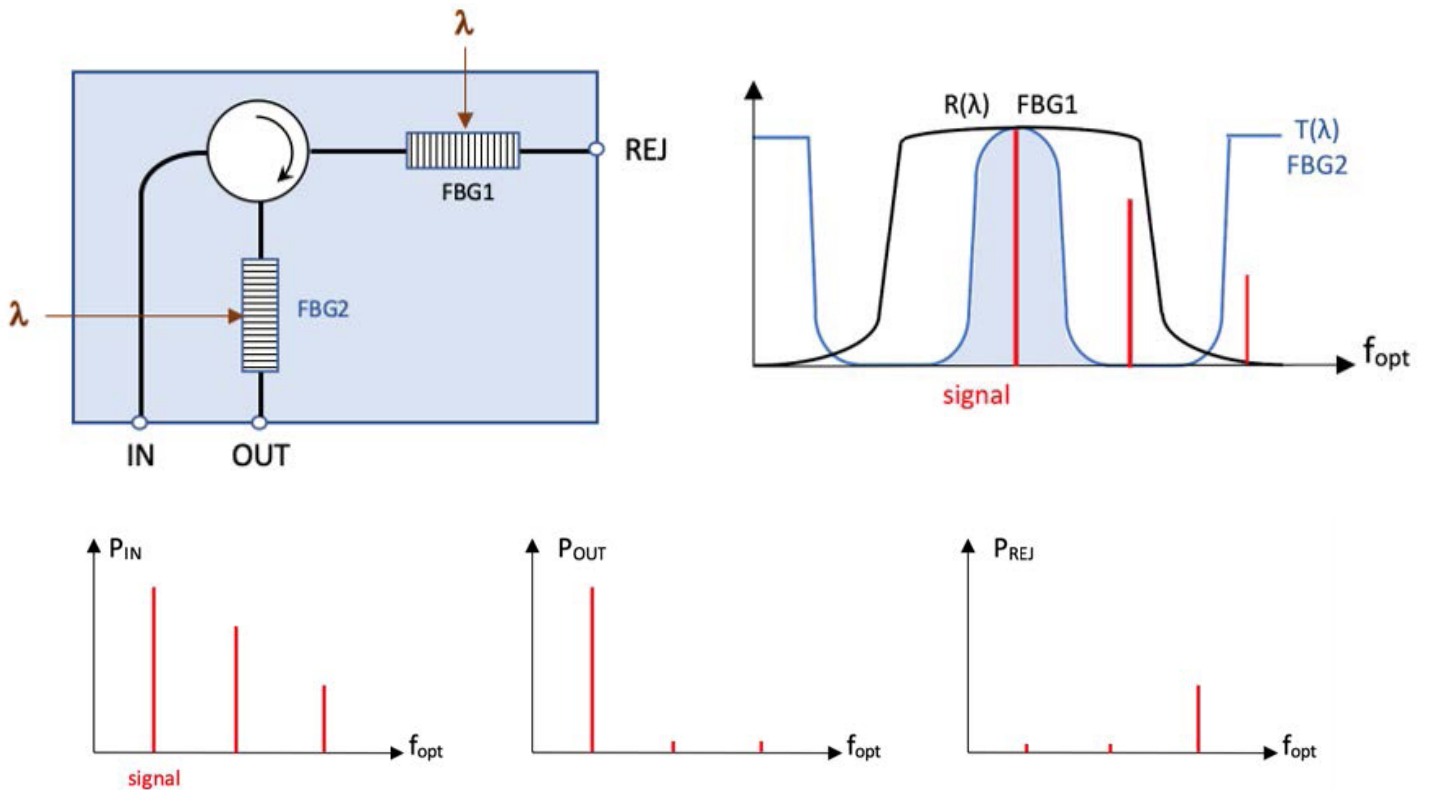

Optical filter based on 2 athermal FBGs and a circulator

Exail reserves the right to change, at any time and without notice, the specifications, design, function or form of its products described herein.

contact.photonics@exail.com | www.exail.com
 Europe +33 1 30 08 94 50 | Americas +1 508 745 3487 | APAC +60 11 1623 1698

